

# Installation instructions

## **OPTION - Electric locking system**



Link to  
Technical sheet  
**OPTION - Electric locking system**

scan me



Retrouvez toutes nos solutions  
RIDEAU ALUMINIUM  
DES VEHICULES SPECIAUX  
sur [www.mcd-fr.com](http://www.mcd-fr.com)

## Option

### Electric locking system

1 -> Electro-magnet

2 -> Push button

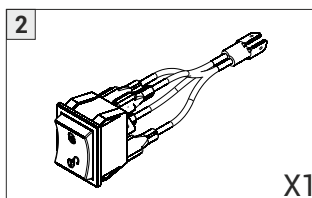
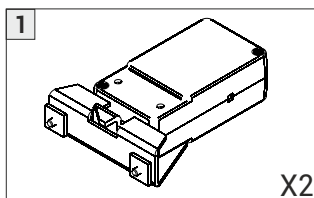

## Electric locking system - Installation perpendicular to the shutter

- 1** Close the shutter in its bottom blocking strikers. Place the electro-magnet at the rear of the tracks and put the bolt in the locked position (bolt extended). Adjust its height to have about 1.5 to 2mm of clearance between the bolt and the lockign rode of the bottom profile.

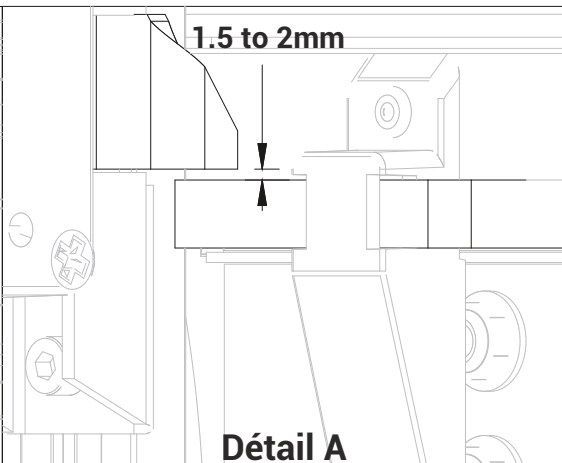
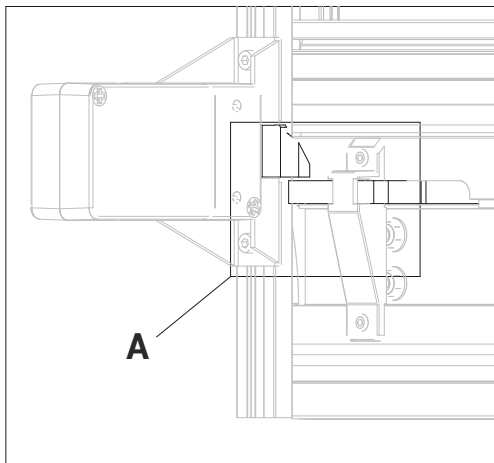
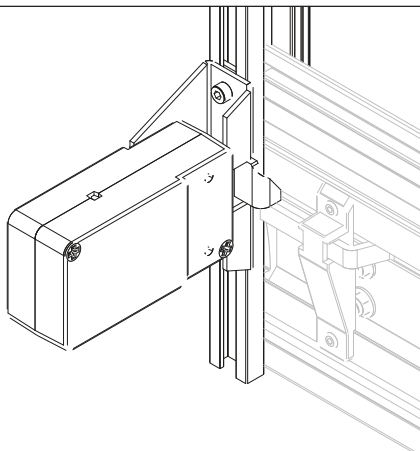
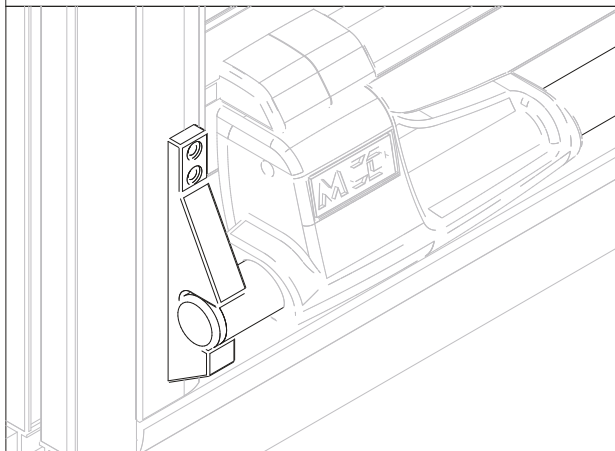

## Electric locking system - Installation parallel to the shutter

- 1 Close the shutter in its bottom blocking strikers. Place the electro-magnet at the rear of the tracks and put the bolt in the locked position (bolt extended). Adjust its height to have about 1.5 to 2mm of clearance between the bolt and the lockign rode of the bottom profile.

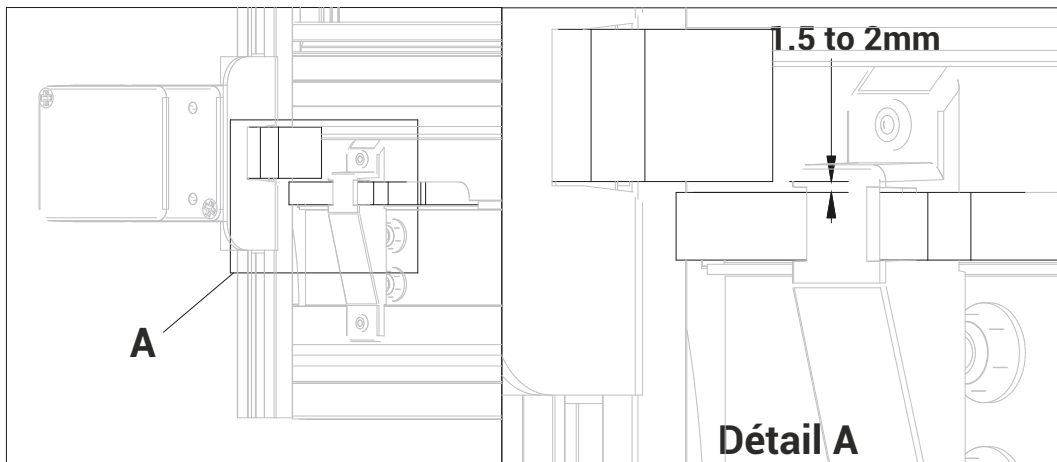
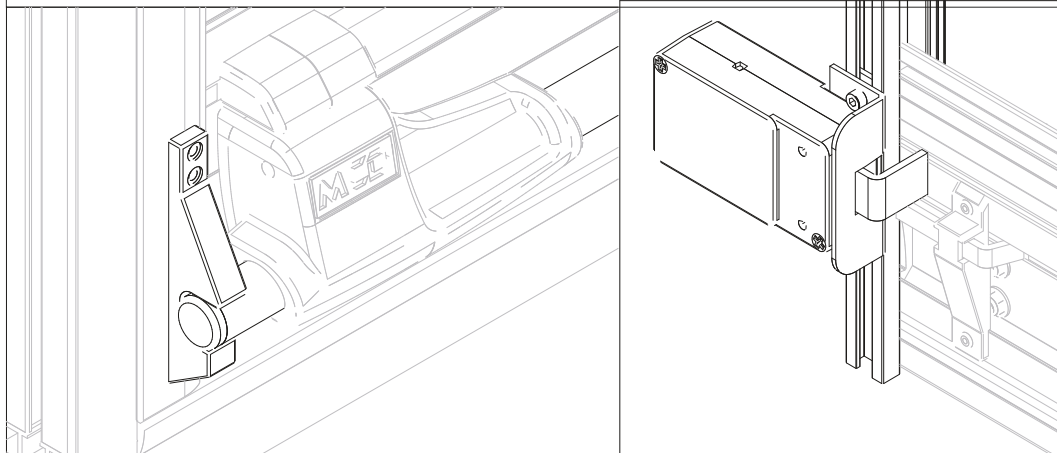

# Wiring diagram electric locking system

